

SCM5B48 ACCELEROMETER INPUT MODULE USER'S MANUAL

Section	Description	Page
1.0	Introduction	1
2.0	CE Compliance	1
3.0	Features and theory of operation	1
4.0	The High Pass filter and the Low Pass Bessel filter	2
5.0	Block diagrams	3
6.0	Wiring diagram	4

1.) INTRODUCTION

The SCM5B48 is a universal Accelerometer Input Signal Conditioning Module with configurable parameters which allow it to interface to a wide range of acceleration sensors. Signal gain, excitation current, AC coupling, and Low Pass filter bandwidth are all configurable using miniature slide switches on the bottom of the module as shown in Figure 1. Product labeling, shown in Figure 2, provides an easy guide for configuration.



Figure 1



Figure 2

2.) CE COMPLIANCE

The SCM5B48-01 is compliant with EMC standards 61000-6-4, ISM, Group 1. Performance for radiated and conducted emissions meets Class A requirements. The module is also compliant with EN61000-6-2 standards for RF immunity, meeting Performance A standards with $\pm 0.5\%$ typical accuracy deviation.

3.) FEATURES AND THEORY OF OPERATION

The SCM5B48 is powered from a single +5VDC source and consumes to 670mW based on configuration. The module provides a 4mA or 9mA excitation current to the sensor with a nominal compliance voltage of +24VDC. Low impedance sensors typically have an output impedance of less than 100 Ω . When interfaced to the SCM5B48 module with 150k Ω minimum input impedance, there is no resulting signal degradation. A voltage mode sensor (ICP[®]*, IEPE* or LIVM*) outputs a signal with an AC component representing acceleration, riding on top of a positive DC bias.

The compliance voltage provided by the SCM5B48 module and the DC bias voltage from the sensor determine the available dynamic range of the sensor and the maximum input for the SCM5B48. The required compliance voltage (VC) for standard ICP[®]* sensors is between 18V and 30V while the sensor output DC bias voltage (VB) is between 8V and 13V. The value of VB will vary by sensor type and manufacturer. Refer to sensor datasheets to determine the value for the particular sensor used. Figure 3 shows a typical accelerometer output signal.

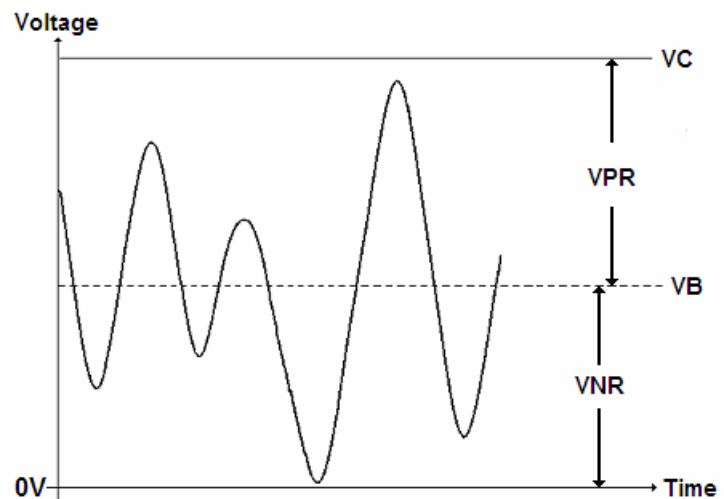

Figure 3 - Sensor Output Signal

*ICP is a registered trademark of PCB Group Inc.

*IEPE is Integrated Electronic Piezo-Electric

*LIVM is Low Impedance Voltage Mode

The sensor output positive range is expressed as:

$$VPR = VC - VB$$

For the SCM5B48,

$$VPR = 24V - VB, \text{ which is equivalent to } 11V \text{ min and } 16V \text{ max}$$

Similarly, the sensor output negative range is:

$$VNR = VB, \text{ which is equivalent to } 8V \text{ min and } 13V \text{ max}$$

The peak sensor output voltage, including both AC and DC components is:

$$V_{\text{peak}} = VC$$

The compliance voltage of the SCM5B48 has a 10% tolerance, which leads to **$V_{\text{peak}} = 21.6V \text{ max}$** to ensure performance at $V_s = 5.00V$ and $T_a = 25C$.

The SCM5B48 has a maximum signal input range of $\pm 10V$ for $G=1$. Therefore, $VPR+VNR$ must be less than $20V_{p-p}$ to prevent clipping. Specified performance is not guaranteed beyond this level. In this configuration, the sensor output DC bias must be removed using the module AC coupling setting in order for the signal to pass through the SCM5B48 module without clipping.

If sensors with lower amplitude output signals are used, the module has selectable gains of 1, 10 and 100. For calibration or setup purposes, the sensor output DC bias voltage may be preserved and amplified using the DC coupling setting. However, the peak sensor output voltage, V_{peak} , multiplied by the selected signal gain, must not exceed $+10V$.

A key feature of the SCM5B48 is a high performance isolation barrier. This can be used to great advantage in industrial applications to break ground loops, allow operation at high common mode voltages, and reject large common-mode spikes, all of which contribute to preserving signal integrity and maintaining a high level of accuracy and low output noise. Additionally, since the module is intended to be used in rugged environments, signal inputs and excitation output on the field-side are protected against accidental connection of voltages up to $240V_{rms}$.

Housed in a solid encapsulant in a thermoplastic shell with a flammability rating of UL-94 V-0, the module has superior chemical, humidity, and vibration resistance. It operates in ambient temperatures from $-40C$ to $+85C$. Designed with precision components, it has excellent electrical stability over time and temperature and does not require recalibration after changes in configuration.

4.) THE HIGH PASS FILTER AND LOW PASS BESSEL FILTER

Sensor coupling to the module can be either DC or AC. For AC coupling, High Pass cutoff frequencies of 0.2Hz and 10Hz can be selected. This two-pole circuit is located on the field-side of the module, prior to amplification, for optimal performance.

Low Pass filtering eliminates frequency content and spurious noise outside the band of interest and provides the lowest noise signal from the module. The SCM5B48 has a 5-pole filter with a Bessel characteristic for optimal frequency and time domain response. One pole of filtering is located on the field-side of the isolation barrier for anti-aliasing, and the remaining four poles are located on the system side. Using the miniature slide switches, the cutoff frequency of the low pass filter can be set to 2.5kHz, 5kHz, 10kHz, or 20kHz.

The choice of High Pass and Low Pass filter cutoff frequencies determines the overall frequency response of the module and is represented by the Bode diagram shown below in Figure 4. Frequency f_{HP} represents the two possible High Pass -3dB frequency settings and frequency f_{LP} represents the four possible Low Pass -3dB frequency settings. Above f_{HP} and below f_{LP} , the signal is attenuated, but to a level less than -3dB. Frequencies f_{ML} and f_{MH} represent the signal frequency at which signal attenuation is less than -0.2% of the output span of the module, which is within the typical accuracy rating. Table 1 below lists numerical data for the eight possible filter settings.

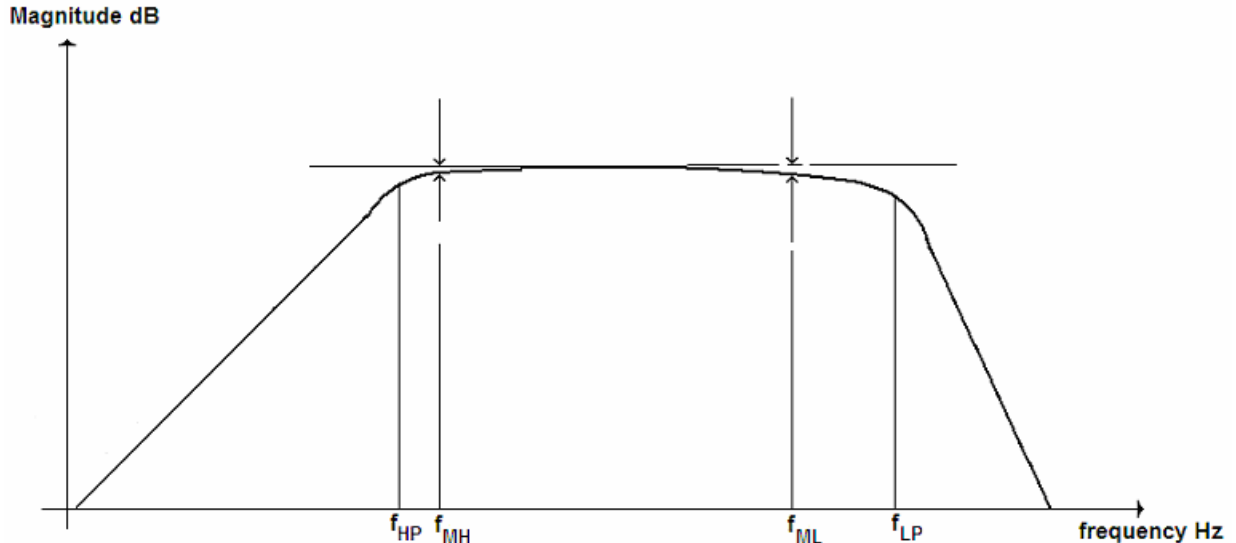

Figure 4 – Bode diagram of the module transfer function.

f _{HP}	f _{LP}	f _{ML}	f _{MH}
0.2Hz	2.5kHz	3Hz	230Hz
10Hz	2.5kHz	170Hz	230Hz
0.2Hz	5kHz	3Hz	600Hz
10Hz	5kHz	170Hz	600Hz
0.2Hz	10kHz	3Hz	1430Hz
10Hz	10kHz	170Hz	1430Hz
0.2Hz	20kHz	3Hz	3100Hz
10Hz	20kHz	170Hz	3100Hz

Table 1

5.) BLOCK DIAGRAM

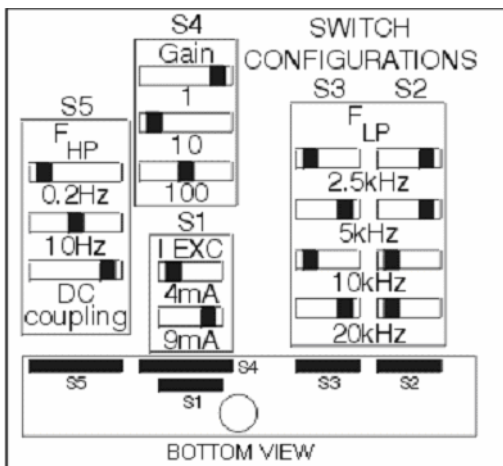

Figure 5 – SCM5B48 Side Label

A side label on the SCM5B48 details the possible settings of the slide switches and indicates the switch locations on the bottom of the module. The slide switches can be easily set using a common fine-tip screwdriver or tweezers.

Figure 6 is a block diagram representing the internal circuitry of the module and how the switches are used to provide configuration. Interface to the backpanel terminal block is also shown. The SCM5B48 can be mounted in any of the standard Dataforth backpanels. Single, dual, eight and 16 position options are available. The module can be mixed and matched with any other SCM5B module.

As indicated on the side label and block diagram, switch S5 sets the two High Pass frequencies or DC coupling, switch S4 sets the signal three gains, switch S1 enables the 4mA or 9mA excitation current, and a combination of switches S3 and S2 determines the selection of one of the four Low Pass filter frequencies.

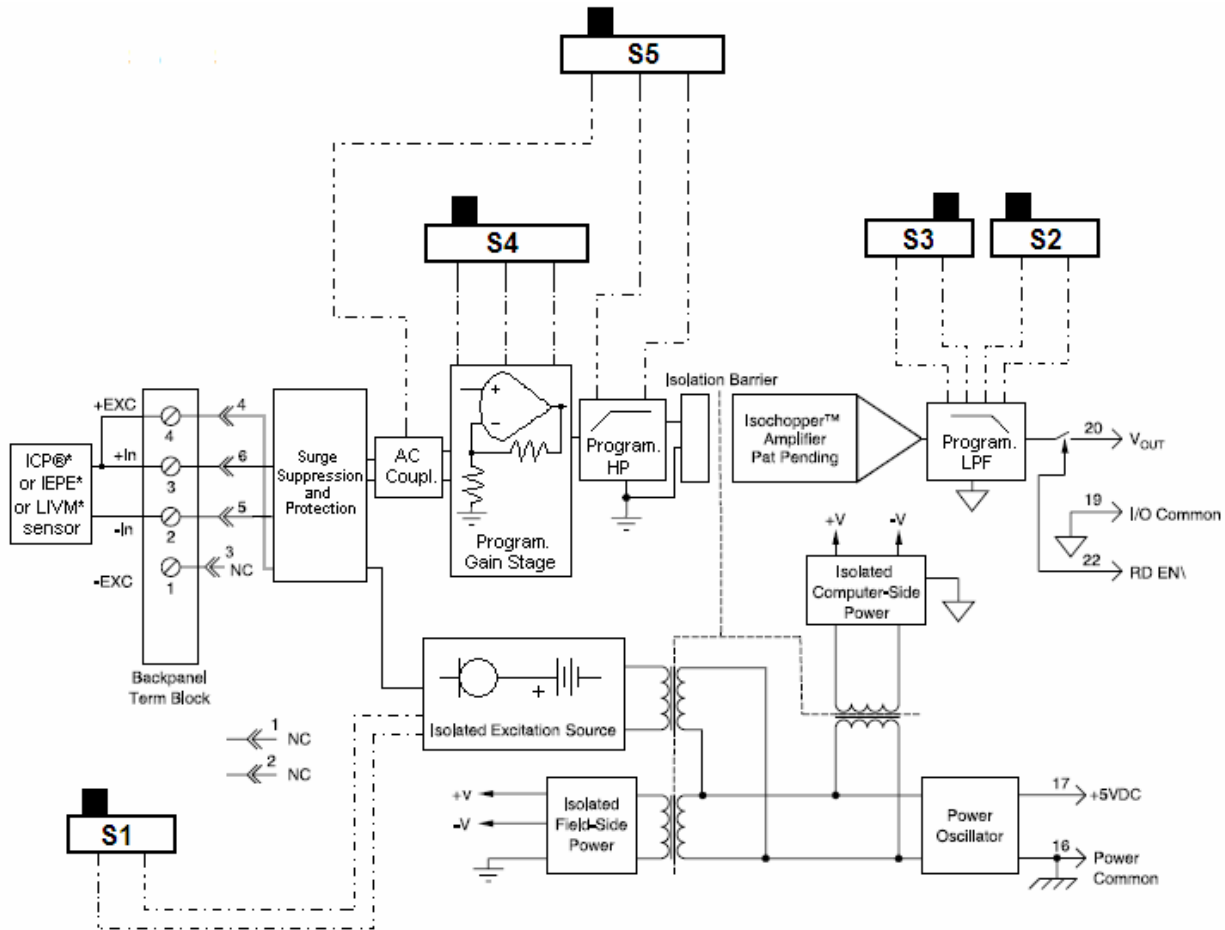

Fig. 6 – SCM5B48 Block Diagram

6.) WIRING DIAGRAM

The SCM5B48 uses a standard SCM5B pin assignment.

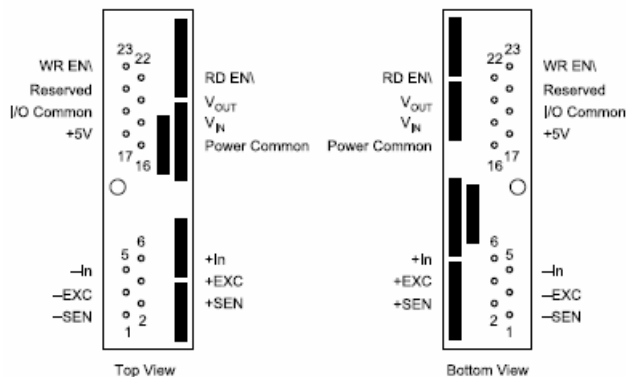

Figure 7 - SCM5B48 Pinout

Pin #	Description	Comment
1	-SENSE	Not connected
2	+SENSE	Not connected
3	-EXC	Not connected
4	+EXC	Must Jumper to +IN
5	-IN	To Sensor -
6	+IN	To Sensor +
16	PCOM	Power Supply -
17	+5V	Power Supply +
18	VIN	Not connected
19	I/O COM	Module Output -
20	VOUT	Module Output +
21	RES	Not connected
22	RD EN\	Output Switch, Active Low
23	WR EN\	Not connected

Table 2 – SCM5B48 Pinout Definition

Each module has an internal output switch which allows it to be multiplexed onto a common analog bus using the SCMPB02 or SCMPB06 backpanels. The switch is controlled with the active low signal RD EN\ and can be continuously enabled by connecting pin 22 to I/O Common, pin 19.

Interfacing the SCM5B48 to acceleration sensors may require a variety of connectors including a Mini coax to two-pin style. ICP®* sensors usually require ordinary two-wire cables. The SCM5B48 has a terminal block interface to the sensor and requires a two-wire cable cutoff end to connect the sensor.

A typical connection using an SCMPB04 backpanel is shown below. Refer to <http://www.dataforth.com/catalog/pdf/scm5baccs.pdf> for further details on this and other standard backpanels.

For sensor interface, the A wire, or signal + is connected to the +IN terminal of the module, and the B wire, or signal - is connected to the -IN terminal. The constant current excitation exits the module on the +EXC terminal and returns to the -IN terminal. For two-wire sensors, the +EXC terminal must be connected to the +IN terminal in order to provide the excitation to the sensor.

If a shielded cable (wire S) is used to connect the sensor to the module, shield grounding will vary by application. If the shield is grounded at the sensor, and the sensor is in turn grounded, no shield connection is required. However, if the shield is not grounded at the sensor or the sensor is floating, the shield can be connected to the -IN terminal of the module to preserve signal integrity.

For the connection shown, the module output is monitored at the Vout and I/O COM terminals.

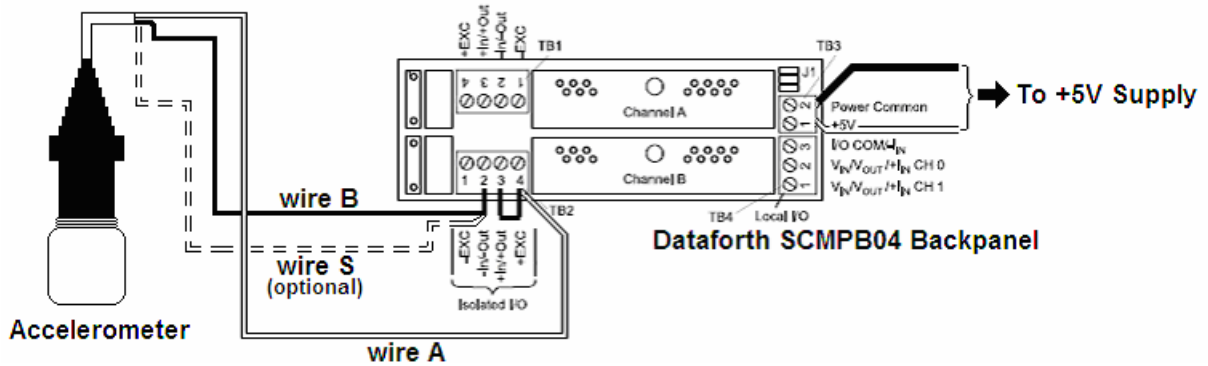

Figure 8 – Wiring Diagram.